

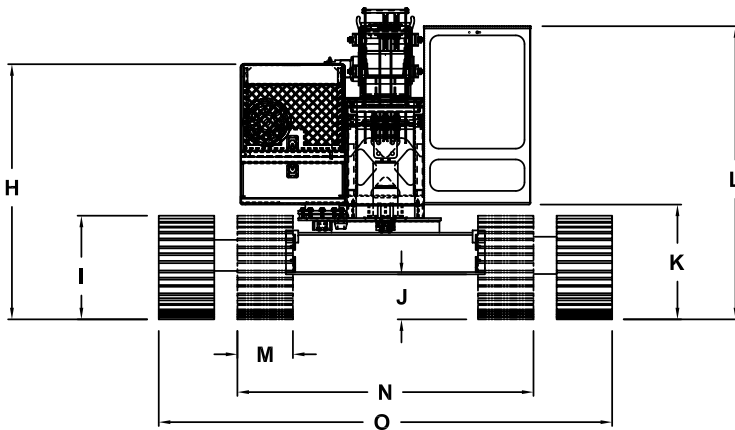

# SPECIFICATIONS

## MANTIS® 3612LP 18 TON TELE-BOOM CRAWLER CRANE

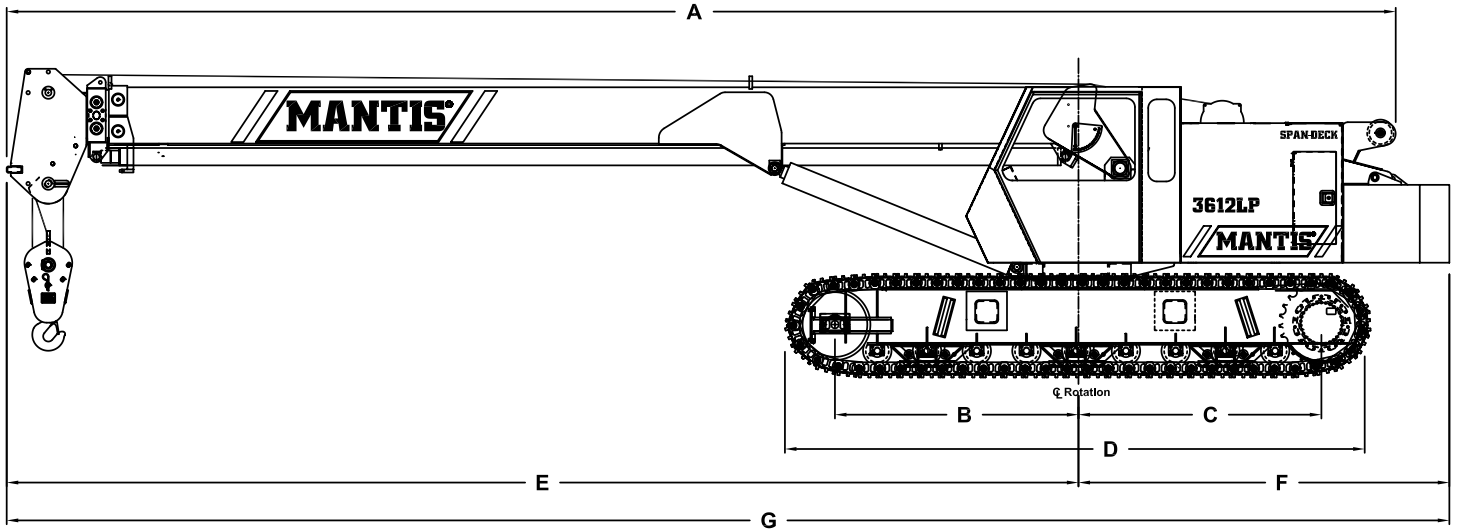

### PRINCIPAL DIMENSIONS

Dimension	Description	Value
A	Length (Counterweight Removed)	37 ft 10 in (11.53 m)
B	CL Front Track Drive to CL Rotation	79 in (2.01 m)
C	CL Rear Track Drive to CL Rotation	78 in (1.98 m)
D	Track Length	15 ft 10 in (4.83 m)
E	Boom Length to CL Rotation (Retracted)	29 ft 6 in (8.99 m)
F	Tailswing	10 ft 0 in (3.05 m)
G	Overall Length	39 ft 6 in (12.04 m)
H	Ground to Top of Engine Cover	87 in (2.21 m)
I	Track Height	34 in (864 mm)
J	Ground Clearance	13 in (330 mm)
K	Ground to Bottom of Cab	37 in (940 mm)
L	Maximum Overall Height	95 in (2.41 m)
M	Track Width	18 in (457 mm)
N	Overall Width (Tracks Retracted)	8 ft 0 in (2.44 m)
O	Overall Working Width (Tracks Extended)	12 ft 3 in (3.73 m)

### WIDTHS, WEIGHTS, AND GROUND PRESSURES\*

Shoe Width	Overall Width		Area	Ground Pressure	Working Weight
	Retracted	Extended			
18 in (457 mm)	8 ft 0 in (2.44 m)	12 ft 3 in (3.73 m)	5,652 in <sup>2</sup> (3.65 m <sup>2</sup> )	9.0 psi (0.63 kg/cm <sup>2</sup> )	50,602 lb (22,953 kg)
24 in (610 mm)	9 ft 0 in (2.74 m)	12 ft 9 in (3.89 m)	7,536 in <sup>2</sup> (4.86 m <sup>2</sup> )	6.9 psi (0.48 kg/cm <sup>2</sup> )	51,761 lb (23,479 kg)
30 in (762 mm)	10 ft 0 in (3.05 m)	13 ft 3 in (4.04 m)	9,420 in <sup>2</sup> (6.08 m <sup>2</sup> )	5.6 psi (0.39 kg/cm <sup>2</sup> )	52,917 lb (24,003 kg)

\* Crane equipped with 71 ft boom, extension, jib, 18 ton hook block, and 7 ton headache ball



# SPECIFICATIONS

## MANTIS® 3612LP 18 TON TELE-BOOM CRAWLER CRANE

### STANDARD CRANE AND EQUIPMENT

---

#### Boom

The main boom consists of three fully powered sections. Retracted length is 29 ft 5 in (8.97 m) and extended length is 71 ft 4 in (21.67 m). Maximum tip height is 76 ft 3 in (23.24 m).

#### Boom Telescoping & Elevating Systems

The elevating system features two cylinders and counterbalance lock valves which provide boom elevations from -1° to 78°. The telescoping system features a single double-acting hydraulic cylinder and counterbalance lock valves preventing the cylinder from retracting under load.

#### Boom Head

Four 12 in (305 mm) diameter steel sheaves on heavy-duty roller bearings are mounted in the boom head.

### SUPERSTRUCTURE

---

#### Frame

The frame is an all-steel, welded structure, precision machined to accept attachment of the boom and swing components.

#### Operator's Cab

The fully-enclosed, air conditioned all-steel modular cab includes a lockable swinging door, acoustical lining, anti-slip floor and tinted safety glass. Sliding windows are located in the cab door and cab boom side. A vent window is positioned in the rear of the cab. Grab bars and steps are appropriately located for easy access to the cab. Erectable swing barricades are attached to the superstructure. Rear view cameras are appropriately located as are work lights.

Standard cab accessories include a two-speed windshield wiper, top glass wiper, defroster, heater, circulating fan, adjustable hand and foot throttles, six-way adjustable fabric seat with headrest, seat belt, dome light, and a dry-chemical fire extinguisher.

#### Instrumentation

Dash instrumentation features a tachometer, voltmeter, oil pressure gauge, temperature gauge, hour meter and fuel gauge. Indicators are provided for crane level, load moment, drum rotation, air filter restriction, hydraulic oil temperature and filter restriction, engine oil pressure and temperature.

A termination switch is located in the seat and armrest and is capable of immediately disabling all hydraulic functions as the operator rises from the seat or it can be activated by lifting the left hand armrest.

#### Control

Two-way hydraulic joysticks mounted in the armrests of the operator's seat control swing, boom extend, main winch and boom hoist. Three two-way hydraulic foot pedals control the travel and swing service brake functions. Travel pedal hand levers are available as an option. A fourth pedal controls engine speed.

#### Counterweight

The 10,000 lb (4,536 kg) single piece counterweight can be removed and installed via a pendant attached to the boom.

#### Load Moment Indicator & Anti-Two Block<sup>1</sup>

Standard Rated Capacity Limiter and Anti-Two Block system includes audible and visual warnings and function shutdown. The system's LCD screen provides a continuous electronic display of working boom length, boom angle, working load radius, tip height, parts-of-line (operator set), machine track configuration (operator set), relative load moment, maximum permissible load and actual load. The standard Work Area Definition audio and video warnings aid the operator in avoiding job-site obstructions by pre-setting and defining the work area. The anti-two block weight allows quick reeving of hook blocks and sends an audible alarm of imminent two-block conditions.

#### Swing

The superstructure rotates 360° on an external gear shear ball slew bearing bolted to the superstructure and the carbody. The hydraulic swing drive powers the system and consists of a gear motor driving a planetary gear reducer with a shaft mounted pinion, providing infinitely variable speeds of up to 3 rpm.

Swing braking is achieved through a "failsafe", hydraulically released, spring applied, multi-disc brake which includes a foot applied service brake. Alternatively, the brake can be electrically actuated through a cab mounted switch into a "locked-on" (parking) mode. A two position house lock system is included. Regular lubrication of the bearing is achieved through a cab mounted grease applicator.

#### Fuel System

A 55 US gal (208 liter) tank is bolted to the superstructure. The fuel filtration system consists of an inline fuel/water separator as well as an engine mounted fuel filter.

#### Hydraulic System

The load sensing, open-loop hydraulic system is served by two variable volume pumps mounted in tandem. The pumps are torque limiting and pressure compensated providing a maximum output of 115 gpm (437 l/min) @ 2,200 rpm and maximum operating pressure of 4,850 psi (339.5 kg/cm<sup>2</sup>). An extra circuit is included for ready adaptation to hydraulic accessories.

The system includes two pilot operated valve banks that are pressure and flow compensated. The 150 US gal (568 liter) capacity hydraulic oil reservoir has a spin-on filler-breather cap, external sight gauge, clean-out access and a sump type drain. Hydraulic oil filtering is achieved with two 5 micron full flow cartridge type filters designed to return in-tank with bypass protection and an electronic bypass indicator.

(System pressure test ports with quick disconnect fittings are provided for diagnostic purposes.)



# SPECIFICATIONS

## MANTIS® 3612LP 18 TON TELE-BOOM CRAWLER CRANE

### MAIN HOIST

Planetary geared single-speed winch includes a bent axis, variable displacement hydraulic motor and a multi-disc internal brake. Wire Rope: 400 ft (122 m) 9/16 in (14 mm) 6 x 37 EIPS, IWRC, RRL Line pulls are not based on wire rope strength, Drum rotation indicator is standard.										
Rope Layer	Maximum Line Pull		Full Load Line Speed		Pitch Diameter		Layer		Total	
1	12,000 lb	5,440 kg	182 ft/min	55.5 m/min	10.3 in	261.9 mm	66 ft	20.1 m	66 ft	20.1 m
2	10,800 lb	4,900 kg	196 ft/min	59.7 m/min	11.3 in	286.8 mm	72 ft	22.0 m	138 ft	42.1 m
3	9,850 lb	4,470 kg	205 ft/min	62.5 m/min	12.3 in	311.6 mm	79 ft	23.9 m	217 ft	66.1 m
4	9,000 lb	4,080 kg	214 ft/min	65.2 m/min	13.2 in	336.4 mm	85 ft	25.8 m	302 ft	91.9 m
5	8,350 lb	3,790 kg	222 ft/min	67.7 m/min	14.2 in	361.2 mm	91 ft	27.7 m	393 ft	119.6 m

### AUXILIARY HOIST

Planetary geared single-speed winch includes a bent axis, variable displacement hydraulic motor and a multi-disc internal brake. Wire Rope: 250 ft (76 m) 9/16 in (14 mm) 6 x 37 EIPS, IWRC, RRL Line pulls are not based on wire rope strength. Drum rotation indicator is standard.										
Rope Layer	Maximum Line Pull		Full Load Line Speed		Pitch Diameter		Layer		Total	
1	12,000 lb	5,440 kg	182 ft/min	55.5 m/min	10.3 in	261.9 mm	66 ft	20.1 m	66 ft	20.1 m
2	10,800 lb	4,900 kg	196 ft/min	59.7 m/min	11.3 in	286.8 mm	72 ft	22.0 m	138 ft	42.1 m
3	9,850 lb	4,470 kg	205 ft/min	62.5 m/min	12.3 in	311.6 mm	79 ft	23.9 m	217 ft	66.1 m
4	9,000 lb	4,080 kg	214 ft/min	65.2 m/min	13.2 in	336.4 mm	85 ft	25.8 m	302 ft	91.9 m
5	8,350 lb	3,790 kg	228 ft/min	69.5 m/min	14.2 in	361.2 mm	91 ft	27.7 m	393 ft	119.6 m

### STANDARD ENGINE

Cummins QSB173 (QSB5.9) (U.S. EPA Tier 3)					
Noise Emissions: Top 96.3 dBa (excludes noise from intake, exhaust, cooling system and driven components)					
Type	6 Cylinder Water Cooled	Weight (Wet)	952 lb (432 kg)	Aspiration	Turbocharged & Air Cooled
Displacement	359 cu in (5.9 l)	Oil Capacity	17.2 US quarts (16.3 l)	Air filter	Dry Type
Bore	4.02 in (102 mm)	Rated Horsepower	173 (129kW) @ 2200 rpm	Electrical system	12 volt
Stroke	4.72 in (120 mm)	Peak Torque	590 ft/lb 800 N-m @ 1500 rpm	Alternator	100 amp

### MACHINE WEIGHTS

STANDARD CRANE with 3 SECTION 70 ft (21.34 m) PULL and PIN BOOM, 1 PIECE COUNTERWEIGHT & 18 in (457 mm) TRACK SHOES	49,500 lb	22,450 kg
Crane Less Counterweight	39,500 lb	17,920 kg
Counterweight	10,000 lb	4,536 kg
OPTIONAL EQUIPMENT		
Pull & Pin Boom - 71 ft 4 in (21.73 m) 3 Section (replaces Full Power Boom) *	(1,000) lb	(453) kg
15 ft (4.57 m) A-Frame Jib	440 lb	200 kg
16 ft (4.88 m) to 25 ft (7.62 m) Telescopic Jib (includes Wire Rope)	950 lb	431 kg
Auxiliary Nose Sheave	145 lb	66 kg
Auxiliary Winch with Standard Rope	607 lb	275 kg
7 ton (6 mt) Headache Ball	162 lb	74 kg
18 ton (16 mt) Hook Block	500 lb	227 kg
Auger Ready Package	440 lb	200 kg
Complete Auger Package	1,520 lb	690 kg
60 in (1.52 m) Auger kelly bar	120 lb	54 kg
72 in (1.83 m) Auger kelly bar	140 lb	64 kg

\* Deduction from Standard Crane Weight



# SPECIFICATIONS

## MANTIS® 3612LP 18 TON TELE-BOOM CRAWLER CRANE

### UNDERCARRIAGE

#### Carbody

The steel box type carbody is fabricated with square axles to accept the crawler side frames. The top surface is precision machined to receive the swing bearing.

#### Side Frames

Two welded steel side frames are paired with a track group consisting of nine sealed rollers located on the bottom of the frame. Each frame includes a self-lubricating idler and spring type track tensioning device. Standard track shoes are 30 in (762 mm) wide, 3-bar semi-grousers. Optional shoes are available in 18 in (457 mm) and 24 in (609 mm) widths in both a flat pad and semi grouser configuration. The side frames extend and retract hydraulically and are controlled from the cab.

#### Travel

Each side frame contains a pilot controlled, two-speed track drive. The drives are hydraulic piston motors which propel the crane at a low speed of 2.0 mph (3.2 km/hr) and at a high speed of 3.0 mph (4.8 km/hr). The internal brake system is spring applied and automatically released upon actuation of the travel system.

The hydraulic travel system provides skid steering and track counter rotation and achieves an unladen gradeability of 70%.

### OPTIONAL EQUIPMENT

#### Boom

- **Pull & Pin Boom:** three section boom - The second section is powered via a single external cylinder and the third section is manually "pulled and pinned." Retracted length is 29 ft 5 in (8.97 m) and extended length is 71 ft (21.64 m). Maximum tip height is 76 ft 2 in (23.22 m).

#### Boom Attachments

- **A-Frame Jib:** 15 ft (4.57 m) pendant suspended, underslung and offsetable at 10°, 20° & 30°. Maximum tip height is 90 ft (27.43 m).
- **Telescopic Jib:** 16 ft (4.88 m) to 25 ft (7.62 m) pulled and pinned, pendant suspended, underslung and offsetable at 10°, 20° & 30°. Maximum tip height is 100 ft (30.48 m).
- **Auxiliary Nose Sheave:** quick reeve, single 12 in (305 mm) diameter high-strength, steel sheave mounted on a heavy-duty roller bearing.
- **Wire Rope:** rotation resistant, (non-spin) Dyform-18 HSLR.
- **Headache Ball:** 7 ton (6 mt) ball includes a swivel hook with a safety latch.
- **Hook Block:** 18 ton (16 mt) hook block contains two 12 in (305 mm) diameter steel sheaves mounted on heavy-duty roller bearings with a swivel hook and safety latch.

#### Hydraulic

- **Auger Ready Package:** includes hoses, fasteners and stowage bracket assembly mounted to the base section of the boom with a flow capability of 34 gpm (130 l/min).
- **Complete Auger Package:** adds a two speed auger motor/gear box and one 60 in (1.52 m) kelly bar to the Auger Ready Package.
- **Tool Circuit:** provides 6 gpm (23 l/min) and 12 gpm (45 l/min) at 2,500 psi (176 kg/cm<sup>2</sup>) through a 50 ft (15.24 m) twin hose reel with quick disconnect fittings to operate open center tools.

#### Other Options

- **Free Fall Hoists:** winches are available in controlled free fall configurations.
- **Crane Cab Access Walkway:** a pair of 54.5 in (1.38 m) wide x 25 in (635 mm) deep walkways which attach to both the front and rear of the carbody and allow for easier egress and ingress to the operator's cab when the crane's upper rotating frame is not aligned front to rear.
- **Model WP750 Work Platform:** 36 in x 72 in (914 mm x 1 828 mm), all-steel, two-person platform with a maximum capacity of 750 lb (340 kg). A test weight and boom head adapter are included in the package. Operation and control are by the crane operator from the cab. Radio (RF) controls to enable remote operation from the platform are available.

(See separate WP750 Specification for a complete description of standard and optional Work Platform equipment.)

<sup>1</sup>Load moment indicating and anti-two block systems are operator aids and must never be used in lieu of job site lift planning calculations by the operator which must take into account ground conditions, weather and all other environmental factors prevailing at the time of the lift. Prices and specifications are subject to change at any time without prior notice and are for factory installation at time of original manufacture. F.O.B Plant; Richlands, VA 24641. Illustrations and photographs may show optional equipment. Supersedes all previous issues. Please see [www.mantiscranes.com](http://www.mantiscranes.com) for most current information.