

MANTIS® 9010 45 TON TELE-BOOM CRAWLER CRANE

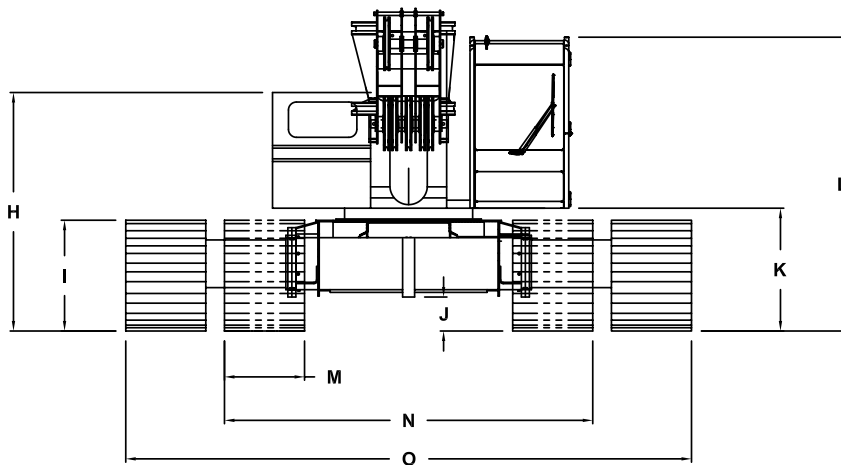
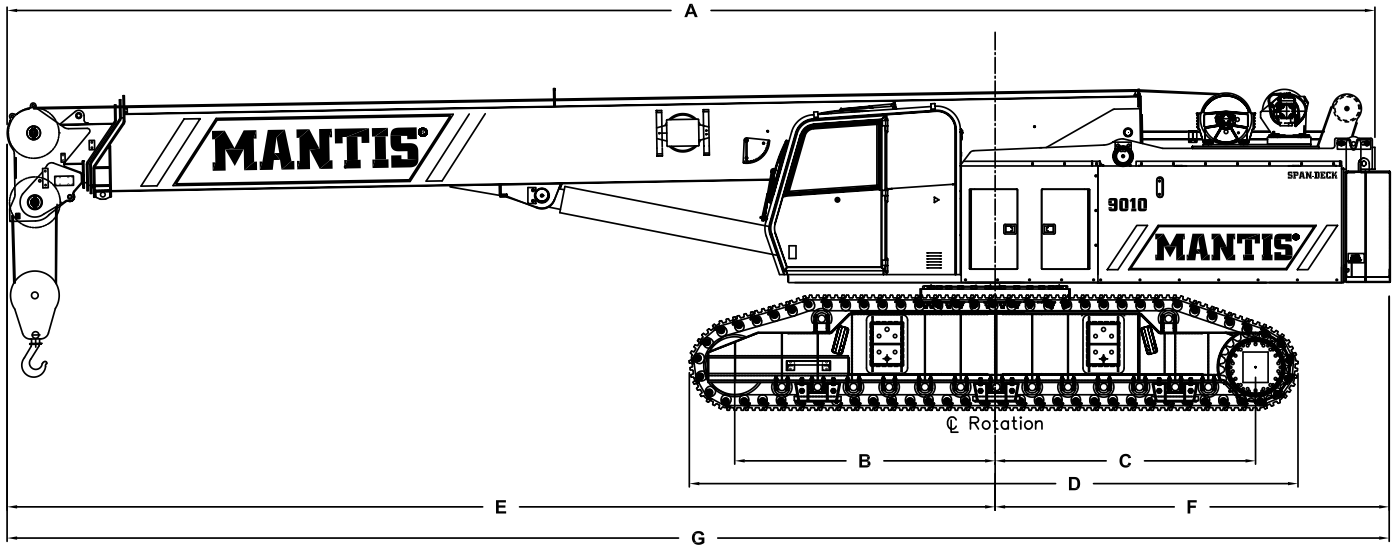

PRINCIPAL DIMENSIONS

Dimension	Description	Value
A	Length (Counterweight Removed)	42 ft 9 in (13.02 m)
B	CL Front Track Drive to CL Rotation	8 ft 2 in (2.46 m)
C	CL Rear Track Drive to CL Rotation	8 ft 2 in (2.46 m)
D	Track Length	19 ft 0 in (5.79 m)
E	Boom Length to CL Rotation	30 ft 10 in (9.40 m)
F	Tailswing	12 ft 10 in (3.91 m)
G	Overall Length	43 ft 7 in (13.29 m)
H	Ground to Top of Engine Cover	8 ft 4 in (2.54 m)
I	Track Height	42 in (1 067 mm)
J	Ground Clearance	13 in (330 mm)
K	Ground to Bottom of Cab	48 in (1 219 mm)
L	Maximum Overall Height	10 ft 0 in (3.05 m)
M	Track Width	36 in (900 mm)
N	Overall Width (Tracks Retracted)	12 ft 0 in (3.66 m)
O	Overall Working Width	18 ft 4 in (5.59 m)

WIDTHS, WEIGHTS, AND GROUND PRESSURES*

Shoe Width	Overall Width		Area	Ground Pressure	Working Weight
	Retracted	Extended			
24 in (609 mm)	11 ft 0 in (3.35 m)	17 ft 2 in (5.22 m)	9,360 in ² (6.04 m ²)	9.6 psi (0.68 kg/cm ²)	89,950 lb (40,800 kg)
30 in (762 mm)	11 ft 6 in (3.51 m)	17 ft 8 in (5.39 m)	11,700 in ² (7.55 m ²)	7.9 psi (0.51 kg/cm ²)	91,930 lb (41,700 kg)
36 in (900 mm)	12 ft 0 in (3.66 m)	18 ft 4 in (5.59 m)	14,040 in ² (9.06 m ²)	6.7 psi (0.47 kg/cm ²)	93,904 lb (42,590 kg)

* Crane equipped with: 105 ft boom, extension, jib, 45 ton hook block, 12 ton headache ball



SPECIFICATIONS

MANTIS® 9010 45 TON TELE-BOOM CRAWLER CRANE

STANDARD CRANE AND EQUIPMENT

Boom

The boom consists of four full power sections, 34 ft 0 in (10.4 m) retracted and 105 ft 0 in (32 m) fully extended. Maximum tip height is 111 ft (33.8 m).

Boom Telescoping & Elevating Systems

The elevating system features a cylinder and counterbalance lock valves which provide boom elevations from -1° to 78°. The telescoping system features two double-acting hydraulic cylinders and counterbalance lock valves.

Boom Head

Six 19 in (483 mm) diameter, cast nylon sheaves on heavy-duty roller bearings are mounted in the boom head.

SUPERSTRUCTURE

Frame

The frame is an all-steel, welded structure, precision machined to accept attachment of the boom and swing devices.

Operator's Cab

The fully-enclosed, air conditioned all-steel modular cab includes a lockable swinging door, acoustical lining, anti-slip floor and tinted safety glass. Sliding windows are located in the cab door and cab boom side. A vent window is positioned in the rear of the cab. Grab bars and steps are appropriately located for easy access to the cab. Erectable swing barricades are attached to the superstructure. Rear view cameras are appropriately located as are work lights.

Standard cab accessories include a two-speed windshield wiper, top glass wiper, defroster, heater, circulating fan, adjustable hand and foot throttles, six-way adjustable fabric seat with headrest, seat belt, dome light, and a dry-chemical fire extinguisher.

Instrumentation

Dash instrumentation features a tachometer, voltmeter, oil pressure gauge, temperature gauge, hour meter and fuel gauge. Indicators are provided for crane level, load moment, drum rotation, air filter restriction, hydraulic oil temperature and filter restriction, engine oil pressure and temperature.

A termination switch is located in the seat and armrest and is capable of immediately disabling all hydraulic functions as the operator rises from the seat or it can be activated by lifting the left hand armrest.

Control

Two-way hydraulic joysticks mounted in the operator's seat armrests control swing, auxiliary hoist, main winch and boom hoist. Four two-way hydraulic foot pedals control travel, swing service brake and boom telescoping functions. A fifth pedal controls engine speed.

Counterweight

The single piece 15,000 lb (6,804 kg) counterweight can be removed and installed via a pendant attached to the boom.

Swing

Load Moment Indicator & Anti-Two Block¹

Standard Rated Capacity Limiter and Anti-Two Block system includes audio and video warnings and control function shutdown. System's LCD screen provides a continuous electronic display of working boom length, boom angle, working load radius, tip height, parts-of-line (operator set), machine track configuration, relative load moment, maximum permissible load and actual load. The standard Work Area Definition audio and video warnings aid the operator in avoiding job-site obstructions by pre-setting and defining the work area. The anti-two block weight allows quick reeving of hook blocks.

The superstructure rotates 360° around a shear ball slew bearing with an external gear that matches with the swing drive pinion and bolts to the superstructure and the carbody. The hydraulic swing drive powers the system and consists of a gear motor driving into a planetary reducer with a shaft mounted pinion providing infinitely variable speeds of up to 3 rpm.

Swing braking is achieved through a "failsafe", hydraulically released, spring applied, multi-disc wet brake which includes a foot applied service brake. The brake can be electrically actuated through a cab mounted switch into a "locked-on" (parking) mode. A two position house lock system is included. Regular lubrication of the bearing is achieved through a cab mounted grease applicator.

Fuel System

An 80 US gal (303 l) tank is bolted to the superstructure. The fuel filtration system consists of an inline fuel/water separator as well as an engine mounted fuel filter.

Hydraulic System

The load sensing, open-loop hydraulic system is served by two variable volume pumps mounted in tandem. The pumps are horsepower limiting providing a maximum output of 168 gpm (636 l/min) @ 2,200 rpm and maximum operating pressure of 4,850 psi (339.5 kg/cm²). An extra circuit is included for ready adaptation to hydraulic accessories.

The system includes two pilot operated valve banks that are pressure and flow compensated. The 300 US gal (1 136 l) capacity hydraulic oil reservoir has a spin-on filler-breather cap, external sight gauge, clean-out access and a sump type drain. An air to oil remote mounted cooler provides oil cooling with thermostatically-controlled, electrically driven fans. Hydraulic oil filtering is achieved with two 3 micron full flow cartridge type filters designed to return in-tank with bypass protection and an electronic bypass indicator.

(System pressure test ports with quick disconnect fittings are provided for diagnostics.)



SPECIFICATIONS

MANTIS® 9010 45 TON TELE-BOOM CRAWLER CRANE

MAIN HOIST

Planetary geared two-speed winch includes a bent axis, variable displacement hydraulic motor and a multi-disc internal brake. Wire Rope: 600 ft (183 m) 5/8 in (16 mm) 6 x 37 EIPS, IWRC, RRL. Line pulls are not based on wire rope strength. Drum rotation indicator is standard.												
Rope Layer	Maximum Line Pull		No Load Line Speed		Full Load Line Speed		Pitch Diameter		Layer		Total	
1	17,500 lb	7,940 kg	384 ft/min	117.0 m/min	179 ft/min	54.6 m/min	11.4 in	288.9 mm	76 ft	23.2 m	76 ft	23.2 m
2	15,700 lb	7,120 kg	414 ft/min	126.2 m/min	193 ft/min	58.8 m/min	12.5 in	316.3 mm	83 ft	25.3 m	159 ft	48.5 m
3	14,300 lb	6,490 kg	433 ft/min	132.0 m/min	202 ft/min	61.6 m/min	13.5 in	343.6 mm	91 ft	27.7 m	250 ft	76.3 m
4	13,100 lb	5,940 kg	451 ft/min	137.5 m/min	210 ft/min	64.0 m/min	14.6 in	370.9 mm	98 ft	29.9 m	348 ft	106.1 m
5	12,100 lb	5,490 kg	482 ft/min	146.9 m/min	225 ft/min	68.6 m/min	15.7 in	398.3 mm	105 ft	32.0 m	453 ft	138.1 m
6	11,300 lb	5,130 kg	489 ft/min	149.0 m/min	228 ft/min	69.5 m/min	16.8 in	425.6 mm	112 ft	34.1 m	566 ft	172.5 m

AUXILIARY HOIST

Planetary geared single-speed winch includes a bent axis, variable displacement hydraulic motor and a multi-disc internal brake. Wire Rope: 350 ft (107 m) 5/8 in (16 mm) 6 x 37 EIPS, IWRC, RRL. Line pulls are not based on wire rope strength. Drum rotation indicator is standard.											
Rope Layer	Maximum Line Pull		Full Load Line Speed		Pitch Diameter		Layer		Total		
1	12,000 lb	5,440 kg	182 ft/min	55.5 m/min	10.4 in	263.5 mm	65 ft	19.8 m	65 ft	19.8 m	
2	10,700 lb	4,850 kg	198 ft/min	60.4 m/min	11.5 in	290.9 mm	66 ft	20.1 m	126 ft	38.4 m	
3	9,800 lb	4,450 kg	208 ft/min	63.4 m/min	12.5 in	318.2 mm	74 ft	22.6 m	199 ft	60.7 m	
4	9,000 lb	4,080 kg	217 ft/min	66.1 m/min	13.6 in	345.5 mm	81 ft	24.7 m	281 ft	85.6 m	
5	8,300 lb	3,760 kg	233 ft/min	71.0 m/min	14.7 in	372.9 mm	89 ft	27.1 m	370 ft	112.8 m	

STANDARD ENGINE

Cummins QSB215 (U. S. EPA Tier 3)					
Noise Emissions: Top 96.3 dBa (excludes noise from intake, exhaust, cooling system and driven components)					
Type	6 Cylinder Water Cooled	Weight (Wet)	1056 lb (479 kg)	Aspiration	Turbocharged & Aftercooled
Displacement	360 cu in (5,9 l)	Oil Capacity	17.2 US quarts (16,3 l)	Air filter	Dry Type
Bore	4.02 in (102 mm)	Rated Horsepower	215 @ 2200 rpm	Electrical system	12 volt
Stroke	4.72 in (120 mm)	Peak Torque	692 ft/lb @ 1500 rpm	Alternator	100 amp

MACHINE WEIGHTS

STANDARD CRANE WITH 4 SECTION 105 ft 0 in (32 m) BOOM, 1 PIECE COUNTERWEIGHT AND 36 in (900 mm) TRACK SHOES	89,900 lb	40,780 kg
Crane Less Counterweight and Track Frames		
Counterweight	15,000 lb	6,800 kg
Track Frames, 2 pieces 11,800 lb (5,350 kg) each	23,600 lb	10,700 kg
OPTIONAL EQUIPMENT		
30 ft (9.14 m) Lattice Extension	1,700 lb	771 kg
20 ft (6.10 m) Jib (connects to head of Lattice Extension ONLY)	700 lb	318 kg
Auxiliary Nose Sheave	210 lb	95 kg
12 ton (11 mt) Headache Ball	404 lb	183 kg
45 ton (40 mt) Hook Block	1,200 lb	544 kg
Auxiliary Winch with Standard Rope	684 lb	311 kg
Auger Ready Package	440 lb	200 kg
Complete Auger Package	1,520 lb	690 kg
60 in (1 524 mm) Auger Kelly Bar	120 lb	54 kg
72 in (1 829 mm) Auger Kelly Bar	140 lb	64 kg

* Deduction from Standard Crane Weight



SPECIFICATIONS

MANTIS® 9010 45 TON TELE-BOOM CRAWLER CRANE

UNDERCARRIAGE

Carbody

The welded steel, box type carbody is fabricated with square axles to accept the crawler side frames. The top surface is precision machined to receive the swing bearing.

Side Frames

Two welded steel removable side frames are paired with a track group consisting of two top and thirteen bottom oil-filled & sealed rollers. Each frame includes an oil-filled, self-lubricating idler and spring type, track tensioning device. Standard track shoes are 36 in (900 mm) wide, 3-bar semi-grousers. Optional shoes are available in 24 in (609 mm) and 30 in (742 mm) widths flat pad and semi grouser configurations. 30 in flat pads are also available. The side frames extend and retract hydraulically and are electrically controlled from the cab.

OPTIONAL EQUIPMENT

Boom Attachments

- **Boom Extension:** 30 ft 0 in (9.1 m), lattice type swingaway that stores alongside of the boom base section and can be used with or without the optional 20 ft 0 in (6.1 m) jib. Head contains two 19 in (483 mm) diameter high strength cast nylon sheaves mounted on heavy-duty roller bearings, reeving up to 2 parts of wire rope. With the extension deployed the maximum tip height is 140 ft (42.7 m).
- **Boom Jib:** 20 ft 0 in (6.1 m) lattice type swingaway, attaches to and stores alongside the extension and can only be used with the extension deployed. Offsets are at 15° & 30°. With jib and extension deployed the maximum tip height is 159 ft (48.5 m).
- **Auxiliary Nose Sheave:** Quick reeve, single 19 in (483 mm) diameter high-strength, cast nylon sheave mounted on a heavy-duty roller bearing.
- **Wire Rope:** rotation resistant, (non-spin,) Dyform-18 HSLR.
- **Headache Ball:** 12 ton (11 mt) ball includes a swivel hook with a safety latch.
- **Hook Block:** 45 ton (40 mt) hook block consists of four 19 in (483 mm) diameter sheaves mounted on heavy-duty roller bearings with a swivel hook and safety latch.

Hydraulic

Travel

Each side frame contains a pilot controlled, two-speed track drive. The drives are hydraulic piston motors which propel the crane at a low speed of 2.0 mph (3.2 km/hr) and at a high speed of 3.0 mph (4.8 km/hr).

The internal brake system is spring applied and automatically released upon actuation of the travel system.

The hydraulic travel system provides skid steering and track counter-rotation and achieves an unladen gradeability of 68%.

- **Auger Ready Package:** includes hoses, fasteners and stowage bracket assembly mounted to the base section of the boom with a flow capability of 40 gpm.
- **Complete Auger Package:** adds a two speed auger motor/gear box and one 60 in (1 524 mm) Kelly bar to the Auger Ready Package.
- **Tool Circuit:** provides 5 gpm (19 l/min) and 10 gpm (38 l/min) at 2,500 psi (176 kg/cm²) through a 50 ft (15.24 m) twin hose reel with quick disconnect fittings to operate open center tools.

Other Options

- **Free Fall Hoists:** all winches are available in free fall and controlled free fall configurations.
- **Crane Cab Access Walkway:** a pair of 54.5 in (1 384 mm) wide x 25 in (635 mm) deep walkways which attach to both the front and rear of the carbody and allow for easier egress and ingress to the operator's cab when the crane's upper rotating frame is not aligned front to rear.
- **Model WP750 Work Platform:** 36 in x 72 in (914 mm x 1 828 mm), all-steel, two-person platform with a maximum capacity of 750 lb (340 kg). A test weight and boom head adapter are included in the package. Operation and control are by the crane operator from the cab. Radio (RF) controls to enable remote operation from the platform are available.

(See separate WP750 Specification for a complete description of standard and optional Work Platform equipment.)